

RACAL INSTRUMENTS
1260-X153
VXI COAXIAL SWITCHING CARD
HIGH FREQUENCY PLUG-IN

PUBLICATION NO. 980914-X153

EADS North America Defense Test and Services, Inc.
4 Goodyear, Irvine, CA 92618
Tel: (800) 722-2528, (949) 859-8999; Fax: (949) 859-7139

info@eads-nadefense.com
sales@eads-nadefense.com
helpdesk@eads-nadefense.com
<http://www.eads-nadefense.com>



PUBLICATION DATE: February 08, 2006

Copyright 2005 by EADS North America Defense Test and Services, Inc. Printed in the United States of America. All rights reserved. This book or parts thereof may not be reproduced in any form without written permission of the publisher.

**THANK YOU FOR PURCHASING THIS
EADS NORTH AMERICA DEFENSE TEST AND SERVICES PRODUCT**

For this product, or any other EADS North America Defense Test and Services, Inc. product that incorporates software drivers, you may access our web site to verify and/or download the latest driver versions. The web address for driver downloads is:

<http://www.eads-nadefense.com/downloads>

If you have any questions about software driver downloads or our privacy policy, please contact us at

info@eads-nadefense.com

WARRANTY STATEMENT

All EADS North America Defense Test and Services, Inc. products are designed and manufactured to exacting standards and in full conformance to EADS ISO 9001:2000 processes.

This warranty does not apply to defects resulting from any modification(s) of any product or part without EADS North America Defense Test and Services, Inc. express written consent, or misuse of any product or part. The warranty also does not apply to fuses, software, non-rechargeable batteries, damage from battery leakage, or problems arising from normal wear, such as mechanical relay life, or failure to follow instructions.

This warranty is in lieu of all other warranties, expressed or implied, including any implied warranty of merchantability or fitness for a particular use. The remedies provided herein are buyer's sole and exclusive remedies.

For the specific terms of your standard warranty, or optional extended warranty or service agreement, contact your EADS North America Defense Test and Services, Inc. customer service advisor. Please have the following information available to facilitate service.

1. Product serial number
2. Product model number
3. Your company and contact information

You may contact your customer service advisor by:

E-Mail:	Helpdesk@eads-nadefense.com	
Telephone:	+1 800 722 3262	(USA)
Fax:	+1 949 859 7309	(USA)

RETURN of PRODUCT

Authorization is required from EADS North America Defense Test and Services, Inc. before you send us your product for service or calibration. Call or contact the Customer Support Department at 1-800-722-3262 or 1-949-859-8999 or via fax at 1-949-859-7139. We can be reached at: helpdesk@eads-nadefense.com.

PROPRIETARY NOTICE

This document and the technical data herein disclosed, are proprietary to EADS North America Defense Test and Services, Inc., and shall not, without express written permission of EADS North America Defense Test and Services, Inc., be used, in whole or in part to solicit quotations from a competitive source or used for manufacture by anyone other than EADS North America Defense Test and Services, Inc. The information herein has been developed at private expense, and may only be used for operation and maintenance reference purposes or for purposes of engineering evaluation and incorporation into technical specifications and other documents which specify procurement of products from EADS North America Defense Test and Services, Inc.

DISCLAIMER

Buyer acknowledges and agrees that it is responsible for the operation of the goods purchased and should ensure that they are used properly and in accordance with this handbook and any other instructions provided by Seller. EADS North America Defense Test and Services, Inc. products are not specifically designed, manufactured or intended to be used as parts, assemblies or components in planning, construction, maintenance or operation of a nuclear facility, or in life support or safety critical applications in which the failure of the EADS North America Defense Test and Services, Inc. product could create a situation where personal injury or death could occur. Should Buyer purchase EADS North America Defense Test and Services, Inc. product for such unintended application, Buyer shall indemnify and hold EADS North America Defense Test and Services, Inc., its officers, employees, subsidiaries, affiliates and distributors harmless against all claims arising out of a claim for personal injury or death associated with such unintended use.

FOR YOUR SAFETY

Before undertaking any troubleshooting, maintenance or exploratory procedure, read carefully the **WARNINGS** and **CAUTION** notices.



CAUTION
RISK OF ELECTRICAL SHOCK
DO NOT OPEN



This equipment contains voltage hazardous to human life and safety, and is capable of inflicting personal injury.



If this instrument is to be powered from the AC line (mains) through an autotransformer, ensure the common connector is connected to the neutral (earth pole) of the power supply.



Before operating the unit, ensure the conductor (green wire) is connected to the ground (earth) conductor of the power outlet. Do not use a two-conductor extension cord or a three-prong/two-prong adapter. This will defeat the protective feature of the third conductor in the power cord.



CAUTION
SENSITIVE ELECTRONIC DEVICES
DO NOT SHIP OR STORE NEAR
STRONG ELECTROSTATIC,
ELECTROMAGNETIC, MAGNETIC OR
RADIOACTIVE FIELDS

Maintenance and calibration procedures sometimes call for operation of the unit with power applied and protective covers removed. Read the procedures and heed warnings to avoid “live” circuit points.

Before operating this instrument:

1. Ensure the proper fuse is in place for the power source to operate.
2. Ensure all other devices connected to or in proximity to this instrument are properly grounded or connected to the protective third-wire earth ground.

If the instrument:

- fails to operate satisfactorily
- shows visible damage
- has been stored under unfavorable conditions
- has sustained stress

Do not operate until, performance is checked by qualified personnel.

Racal Instruments

CE Declaration of Conformity

We

Racal Instruments Inc.
4 Goodyear Street
Irvine, CA 92618

declare under sole responsibility that the

**1260-X153, 10 - 1x4 Coaxial Tree Switch Plug-In,
P/N 408011**

conforms to the following Product Specifications:

EMC: EN61326: 1997 +A1: 1998 +A2: 2001 +A3: 2003 Class A

EN61000-3-2: 2000 +A2: 2005 Class A

EN61000-3-3: 1995 +A1: 2001

Supplementary Information:

The above specifications are met when the product is installed in a Racal Instruments certified mainframe with faceplates installed over all unused slots, as applicable

The product herewith complies with the requirements of the Low Voltage Directive 73/23/EEC and the EMC Directive 89/336/EEC (modified by 93/68/EEC).

Irvine, CA, May 20, 2006

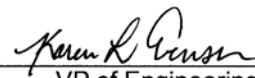
VP of Engineering
Karen Evensen

This page was left intentionally blank.

Table of Contents

Chapter 11-1

SPECIFICATIONS1-1

 Introduction.....1-1

 Specifications1-3

 Power Dissipation.....1-5

 About MTBF1-6

 Ordering Information1-7

Chapter 22-1

INSTALLATION INSTRUCTIONS.....2-1

 Unpacking and Inspection2-1

 Reshipment Instructions2-2

 Installation2-2

 1260-X100 Shield Removal.....2-2

 Module Configurations2-2

 Front Panel Connectors.....2-3

 Mating Connectors.....2-3

 Mating Connector Tools.....2-3

Chapter 3	3-1
MODULE OPERATION	3-1
Setting the Module Address	3-1
VXI Operating Modes	3-1
Operating In VXI Message-Based Mode	3-3
Channel Descriptors For The 1260-X153	3-3
Reply To The MOD:LIST? Command	3-5
Operating in VXI Register-Based Mode	3-6
 Chapter 4	 4-1
PRODUCT SUPPORT	4-1
Product Support	4-1
Warranty	4-1

List of Figures

Figure 1-1, 1260-X1531-2

Figure 2-1, 1260-X153 Relay Diagram – Multiplexers 00-032-5

Figure 2-2, 1260-X153 Relay Diagram – Multiplexers 04-072-6

Figure 2-3, 1260-X153 Relay Diagram Multiplexers 08-112-7

Figure 2-4, 1260-X153 Front Panel2-8

Figure 2-5, 1260-X153 J200/J201 Connector Pin Out.....2-9

Figure 2-6, 1260-X153 Block Diagram.....2-12

Figure 3-1, Message-Based Mode of Operation3-2

Figure 3-2, Register-Based Mode of Operation3-2

List of Tables

Table 2-1, 1260-X153 8:1x4 MUX, 4:1x2 MUX Channel/Pinout Assignments.....2-10

Table 2-2, 1260-X153 4:1x8 MUX, 2:1x4 MUX Channel/Pinout Assignments.....2-11

Table 3-1, Control Register/Relay Assignments3-7

This page was left intentionally blank.

Chapter 1

SPECIFICATIONS

Introduction

The 1260-X153 is a plug-in switch module developed for the 1260-X100 Adapt-a-Switch Carrier. The 1260-X153 includes the following features:

- Standard plug-in design, providing for ease of replacement.
- Data-Driven embedded descriptor, allowing immediate use with any Option-01T switch controller, regardless of firmware revision level.
- Eight 1x4 RF Multiplexers and Four 1x2 Multiplexers.
- 1 GHz Bandwidth
- 50 Ω impedance
- Four 1x8 and Two 1x4 Multiplexer configurable
- High Density Coax Switching

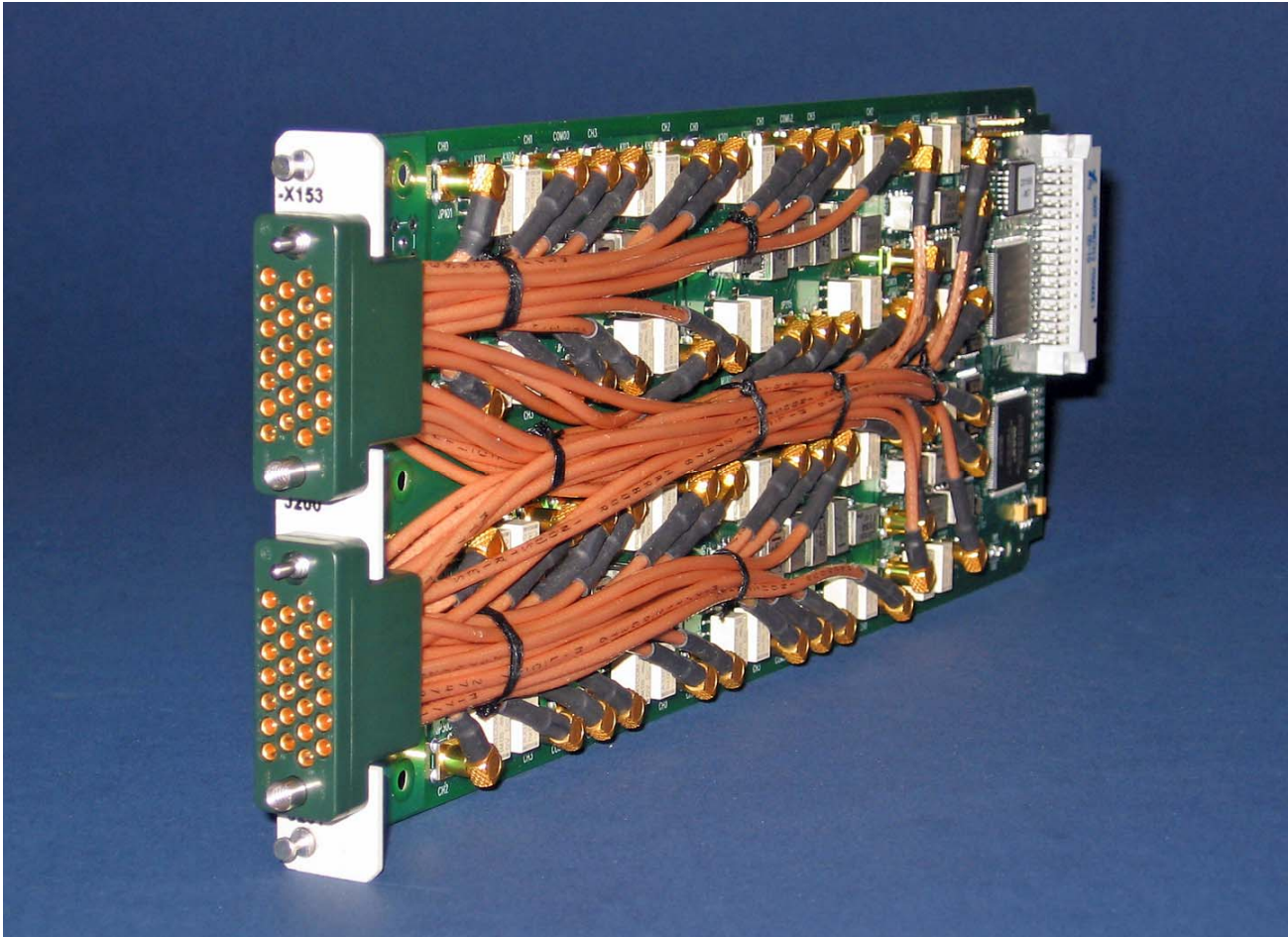

Figure 1-1, 1260-X153

Specifications

Characteristic Impedance	50Ω
Bandwidth (-3dB)	> 1.0GHz
Insertion Loss	≤ 0.4 dB to 100 MHz ≤ 1.2 dB to 500 MHz ≤ 2.0 dB to 800 MHz ≤ 3.0 dB to 1 GHz
Isolation	≥ 70 dB to 1 MHz ≥ 65 dB to 100 MHz ≥ 40 dB to 500 MHz ≥ 30 dB to 1 GHz
Crosstalk	≤ -70 dB to 1.0 MHz ≤ -65 dB to 100 MHz ≤ -45 dB to 500 MHz ≤ -35 dB to 1 GHz
VSWR	≤ 1.1 dB to 100 MHz ≤ 1.6 dB to 500 MHz ≤ 1.8 dB to 1 GHz
Minimum Pulse Width	≥ 4 nsecs (3.5 nsec rise/fall time)
Maximum Switching Voltage	110 VDC or 125VAC
Maximum Voltage	200 VDC or VAC pk
Max Switching Current	1.0 ADC or RMS
Max Carry Current	2.0 ADC or RMS
Max Switching Power	≤ 30 W DC, 37.5 VA AC ≤ 1 W RF

Initial Path Resistance	$\leq 0.5 \Omega$, 0.25 Ω typ.
Capacitance	≤ 100 pF Signal to Chassis ≤ 30 pF Signal Ground to Chassis ≤ 10 pF Open Channel
Insulation resistance	$\geq 10^8 \Omega$ Signal to Chassis $\geq 10^8 \Omega$ Signal Ground to Chassis $\geq 10^9 \Omega$ Open Channel
Relay Settling Time	≤ 10 ms
Shock	30g, 11 ms, 1/2 sine wave
Vibration	0.013 in. P _k -P _k , 5-55 Hz
Bench Handling	4 in., 45°
Cooling	See 1260-X100 cooling data
Temperature	
Operating	0°C to +55°C
Non-operating	-40°C to +60°C
Relative Humidity	85% \pm 5% non-condensing at < 35°C
Altitude	
Operating	10,000 feet
Non-operating	15,000 feet
Power Requirements	
+5 VDC	≤ 200 mA + 21mA per energized relay (1.0 Amps Max.)
Weight	18 oz (.51Kg)
MTBF	>130,000 hours (MIL-HDBK-217E) at 25 degrees C
Dimensions	4.5"H X 0.75"W X 12.8"D

Power Dissipation

While the cooling of the Adapt-a-Switch carrier is dependent upon the chassis into which it is installed, the carrier can normally dissipate approximately 100 W. Care must be taken, then, in the selection and loading of the plug-in modules used in the carrier. It is not possible to fully load the carrier, energize every relay, and run full power through every set of contacts, all at the same time. In practice this situation would never occur.

To properly evaluate the power dissipation of the plug-in modules, examine the path resistance, the current passing through the relay contacts, the ambient temperature, and the number of relays closed at any one time.

For example, if a 1260-X153 module has 30 relays closed, and 10 paths passing a current of 1.0A, then:

$$\begin{aligned} \text{Total power dissipation} = \\ &[(\text{current})^2 * (\text{path resistance}) * (\text{total number of paths})] + \\ &(\text{quiescent power}) \end{aligned}$$

By substituting the actual values:

$$\begin{aligned} \text{Total power dissipation} = \\ &[(1.0 \text{ A})^2 * (.50 \Omega) * 10] + (5 \text{ W}) = 9 \text{ W at } 55^\circ\text{C} \end{aligned}$$

This is acceptable power dissipation for an individual plug-in module. If five additional modules are likewise loaded, then the overall carrier dissipation is approximately 60 W, which is well within the cooling available in any commercial VXIbus chassis. In practice, rarely are more than 25% of the module's relays energized simultaneously, and rarely is full rated current run through every path. In addition, the actual contact resistance is typically one-half to one-fourth the specified maximum, and temperatures are normally not at the rated maximum. The power dissipated by each plug-in should be no more than 15 W if all six slots are used simultaneously. Consult the Power Dissipation Section of any other 1260 Adapt-a-Switch card manuals for additional information.

Most users of a signal-type switch, such as the 1260-X153, switch no more than a few hundred milliamperes and are able to energize all relays simultaneously, should they so desire.

Additionally, if fewer plug-in modules are used, more power may be dissipated by the remaining cards. By using a chassis with high cooling capacity, such as the 1261B, almost any configuration may be realized.

About MTBF

The 1260-X153 MTBF is > 130,000 hours, calculated in accordance with MIL-HDBK-217E at 25 Deg C, including the electromechanical relays. Relays are included in this calculation but overall relay life is strongly dependent upon operating conditions. Factors affecting relay life expectancy are:

1. Switched voltage
2. Switched current
3. Switched power
4. Maximum switching capacity
5. Maximum rated carrying current
6. Load typ (resistive, inductive, capacitive)
7. Switching repetition rate
8. Ambient temperature

The most important factor is the maximum switching capacity, which is an interrelationship of maximum switching power, maximum switching voltage and maximum switching current. When a relay operates at a lower percentage of its maximum switching capacity, its life expectancy is longer. The maximum switching capacity specification is based on a resistive load, and must be further de-rated for inductive and capacitive loads.

For more details about the above life expectancy factors, refer to the data sheet for the switch plug-in module.

The relays used on the 1260-X153 plug-in are P/N 310274-003 and 310346. The manufacturer's endurance specifications for these relays are:

Life Expectancy

Mechanical	50,000,000 operations
Electrical	100,000 operations at full rated load 30W DC, 37.5VA AC, 1W RF resistive
	500,000 operations typ. at loads of 12W DC, 18.75VA AC resistive

For additional relay specifications, refer to the relay manufacturer's data sheet.

Ordering Information

Listed below are part numbers for both the 1260-X153 switch modules and available mating cable accessories. The 1260-X153 uses two high density 26 pin coax connectors with coaxial contacts which are not supplied as part of the 1260-X153 and must be ordered separately.

ITEM	DESCRIPTION	PART #
1260-X153	8:1x4 4:1x2 RF Switch Card, 1 GHz	408011
Housing	26 Pin Housing	602221-126
Coax Pin	Coaxial Mating Pin	602221-903
Cable Assy. 2ft, 50Ω	Single Coax Cable w/ (2) Coax Plugs (can be cut and used as 2 cables)	407746-001
Cable Assy. 6ft, 50Ω	Single Coax Cable w/ (2) Coax Plugs (can be cut and used as 2 cables)	407746-003
Cable Assy. 12ft, 50Ω	Single Coax Cable w/ (2) Coax Plugs (can be cut and used as 2 cables)	407746-006
Additional Manual	User Manual	980914-X153

This page was left intentionally blank.

INSTALLATION INSTRUCTIONS

Unpacking and Inspection



1. Remove the 1260-X153 module and inspect it for damage. If any damage is apparent, inform the carrier immediately. Retain shipping carton and packing material for the carrier's inspection.
2. Verify that the pieces in the package you received contain the correct 1260-X153 module option and the 1260-X153 Users Manual. Notify EADS North America Defense Test and Services, Inc. if the module appears damaged in any way. Do not attempt to install a damaged module into a VXI chassis.
3. The 1260-X153 module is shipped in an anti-static bag to prevent electrostatic damage to the module. Do not remove the module from the anti-static bag unless it is in a static-controlled area.

CAUTION:

ESD sensitive devices, open the instrument at an ESD safe work station.

WARNING:

The 1260-X153 card is a high-frequency switch card. Make absolutely sure, that all the devices maximum ratings are not exceeded. Failure to observe these precautions could result in product damage.

Reshipment Instructions

1. Use the original packing when returning the switching module to EADS North America Defense Test and Services, Inc. for calibration or servicing. The original shipping carton and the instrument's plastic foam will provide the necessary support for safe reshipment.
2. If the original packing material is unavailable, wrap the switching module in an ESD Shielding bag and use plastic spray foam to surround and protect the instrument.
3. Reship in either the original or a new shipping carton.

Installation

Installation of the 1260-X153 Switching Module into a 1260-X100 Carrier assembly is described in the Installation section of the 1260-X100 Adapt-a-Switch Carrier Manual.

1260-X100 Shield Removal

Due to additional space height required for the cabling on the 1260-X153, removal of the 1260-X100 carrier inter-module shields may be required. For details on removal of the shields consult the Installation Section of the 1260-X100 Manual P/N 980914-100X.

Module Configurations

The 1260-X153 series are high frequency coaxial switch modules each containing eight 1x4 and four 1x2 RF multiplexers. The 1260-X153 is implemented as simple RF trees, where only one or no channel can be connected to the common output of a multiplexer.

The 1260-X153 can combine two of each of the 1x4 multiplexers into a single 1x8 multiplexer. It also has the capability to combine two of each of the 1x2 multiplexers into a single 1x4 multiplexer. The user has the flexibility to configure as many 1x2, 1x4 and 1x8 multiplexers as required.

See **Figure 2-1 through Figure 2-3** for the 1260-X153 Relay Diagrams which details all the possible configurations and switching paths. As shown in these diagrams each 1x4 multiplexer pair (i.e. 0/1) shares a common signal ground that is isolated from all other multiplexer pairs as well as chassis ground.

Figure 2-5 shows an overall block diagram of the 1260-X153.

Front Panel Connectors

The 1260-X153 Series uses two 26 pin coaxial connectors as the module interface. **Table 2-1 and 2-2** shows the mapping of I/O connections to channel numbers. **Table 2-1** shows the typical connections for the 1260-X153 when it is configured as 8:1x4 and 4:1x2 Multiplexers. **Table 2-2** shows the typical connections for the 1260-X153 when it is configured as 4:1x8 and 2:1x4 Multiplexers.

A detail of the pinouts of the J200 and J201 connectors is shown in **Figures 2-4 and 2-5**.

Mating Connectors

The 1260-X153 uses two high-density coax plugs for mating connectors.

Mating connectors and cables are not provided as part of the 1260-X153 Shipping Kit. Mating Cable assemblies must be ordered separately. Refer to the Ordering Information section of this manual.

Mating Connector Tools

For the user that chooses to build their own cable assemblies a list of assembly tools is supplied below for various cable types.

Mating connectors and tools are not provided as part of the 1260-X153 Shipping Kit. Mating connectors and tooling must be ordered separately.

Description	Racal P/N	Souriau P/N
Connector	602221-126	MS26PM-118
Pin	602221-903	RMDXK-10D28
Extraction Tool	990922	RX16D11-D1
Crimp Tool Kit (includes items below)	991034	-
Crimp Tool	990923	M10s-1
Stop Bushing	991034-001	SL47-1
Stop Bushing	991034-002	SL46D2
Die Set	991034-003	S26D2
Die Set	991034-004	S23D2
Die Set	991034-005	S22-1

MULTIPIECE Subminiature coax - Male contact for coaxial cable

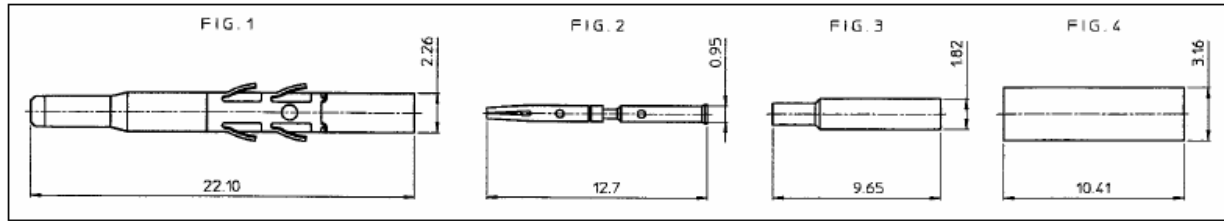

Type of coaxial cable	Contact for inner conductor				Contact for outer braid						Extrac tool
	Inner female contact		Crimp tool M10S1		Outer male contact		Hyring		Crimp tool M10S1		
	Part number	Fig.	Die Set	Stop Bushing	Part number	Fig	Part number	Fig	Die Set	Stop Bushing	
RG 161U RG 179A/U RG 179B/U RG 187U	RFD26L1D28	2	S23D2	SL46D2	RMDX602D28	1	yOC074	4	S22-1	SL47-1	RX2025 GE1
S26D2			yOC074				4				
S23D2			yOC074 + RMDXB0553				4 3				

Kit reference RMDXK10D28 includes RMDX602D28 + RFD26L1D28 + yOC074 + RMDXB0553 and are packed in plastic bag.

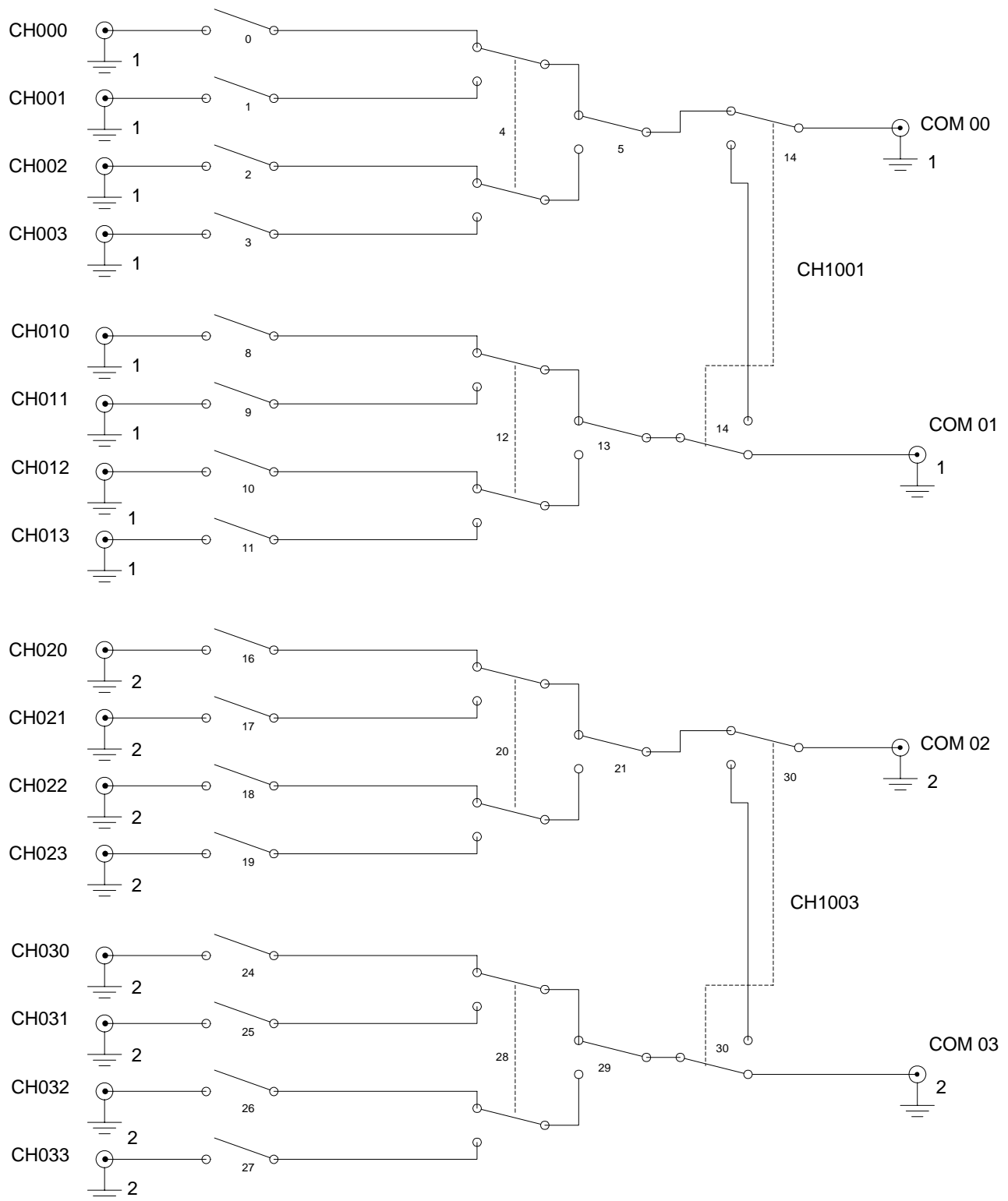

Figure 2-1, 1260-X153 Relay Diagram – Multiplexers 00-03

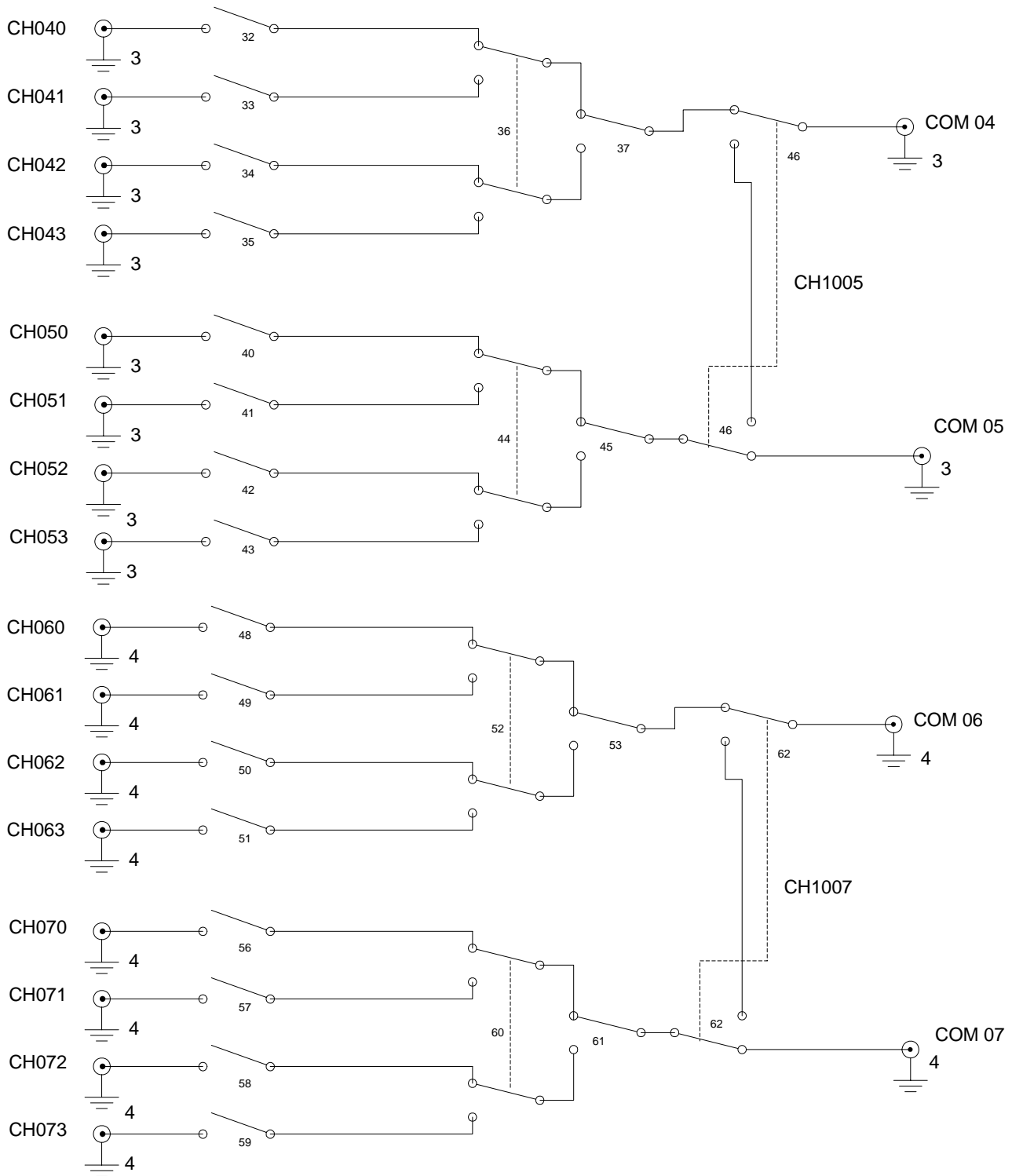

Figure 2-2, 1260-X153 Relay Diagram – Multiplexers 04-07

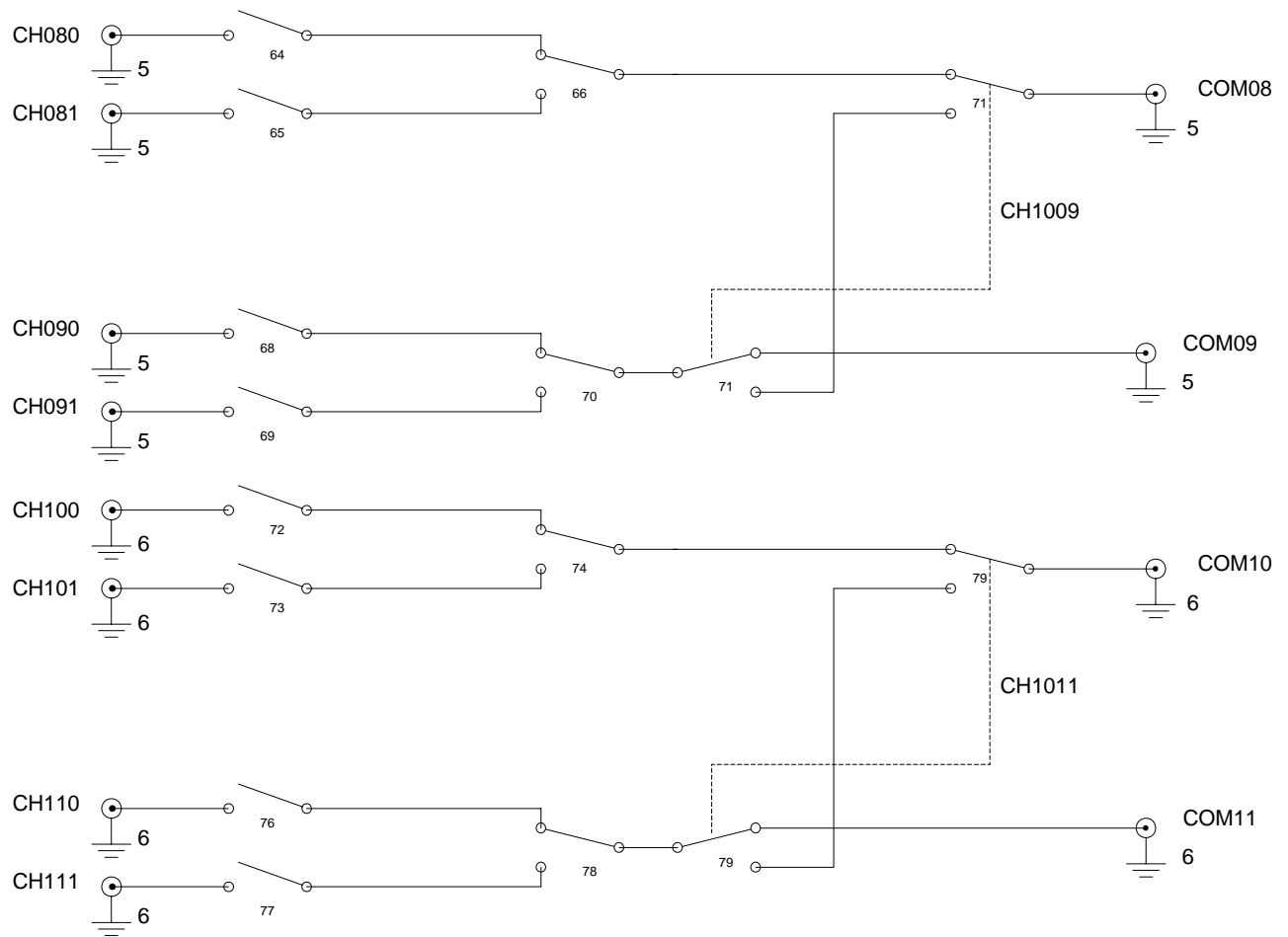

Figure 2-3, 1260-X153 Relay Diagram Multiplexers 08-11

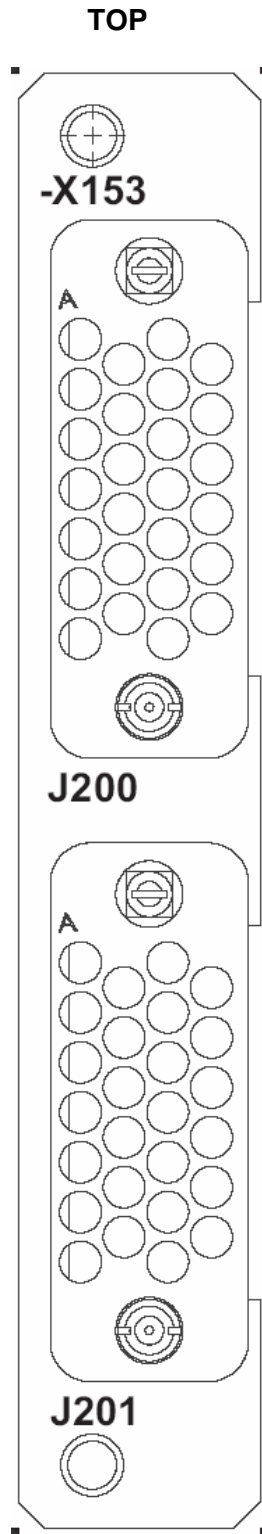

Figure 2-4, 1260-X153 Front Panel

Top

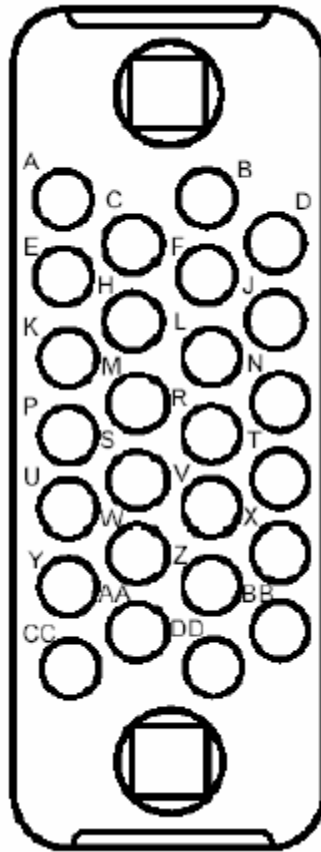

Figure 2-5, 1260-X153 J200/J201 Connector Pin Out

Table 2-1, 1260-X153 8:1x4 MUX, 4:1x2 MUX Channel/Pinout Assignments

8:1x4 MUX, 4:1x2 MUX CONFIGURATION CONNECTOR PINOUTS		
Channel Number	Common Connector Pin	Channel Connector Pin
000	J200-K	J200-A
001	J200-K	J200-E
002	J200-K	J200-P
003	J200-K	J200-U
010	J200-M	J200-W
011	J200-M	J200-S
012	J200-M	J200-H
013	J200-M	J200-C
020	J200-L	J200-B
021	J200-L	J200-F
022	J200-L	J200-R
023	J200-L	J200-V
030	J200-N	J200-X
031	J200-N	J200-T
032	J200-N	J200-J
033	J200-N	J200-D
040	J201-U	J201-K
041	J201-U	J201-P
042	J201-U	J201-Y
043	J201-U	J201-CC
050	J201-S	J201-AA
051	J201-S	J201-W
052	J201-S	J201-M
053	J201-S	J201-H
060	J201-V	J201-L
061	J201-V	J201-R
062	J201-V	J201-Z
063	J201-V	J201-DD
070	J201-T	J201-BB
071	J201-T	J201-X
072	J201-T	J201-N
073	J201-T	J201-J
080	J200-AA	J200-Y
081	J200-AA	J200-CC
090	J200-BB	J200-Z
091	J200-BB	J200-DD
100	J201-C	J201-A
101	J201-C	J201-E
110	J201-D	J201-B
111	J201-D	J201-F

Table 2-2, 1260-X153 4:1x8 MUX, 2:1x4 MUX Channel/Pinout Assignments

1260-X153 4:1x8 MUX, 2:1x4 CONFIGURATION CONNECTOR PINOUTS		
Channel Number	Common Connector Pin	Channel Connector Pin
000	J200-K	J200-A
001	J200-K	J200-E
002	J200-K	J200-P
003	J200-K	J200-U
010 and 1001	J200-K	J200-W
011 and 1001	J200-K	J200-S
012 and 1001	J200-K	J200-H
013 and 1001	J200-K	J200-C
020	J200-L	J200-B
021	J200-L	J200-F
022	J200-L	J200-R
023	J200-L	J200-V
030 and 1003	J200-L	J200-X
031 and 1003	J200-L	J200-T
032 and 1003	J200-L	J200-J
033 and 1003	J200-L	J200-D
040	J201-U	J201-K
041	J201-U	J201-P
042	J201-U	J201-Y
043	J201-U	J201-CC
050 and 1005	J201-U	J201-AA
051 and 1005	J201-U	J201-W
052 and 1005	J201-U	J201-M
053 and 1005	J201-U	J201-H
060	J201-V	J201-L
061	J201-V	J201-R
062	J201-V	J201-Z
063	J201-V	J201-DD
070 and 1007	J201-V	J201-BB
071 and 1007	J201-V	J201-X
072 and 1007	J201-V	J201-N
073 and 1007	J201-V	J201-J
080	J200-AA	J200-Y
081	J200-AA	J200-CC
090 and 1009	J200-AA	J200-Z
091 and 1009	J200-AA	J200-DD
100	J201-C	J201-A
101	J201-C	J201-E
110 and 1011	J201-C	J201-B
111 and 1011	J201-C	J201-F

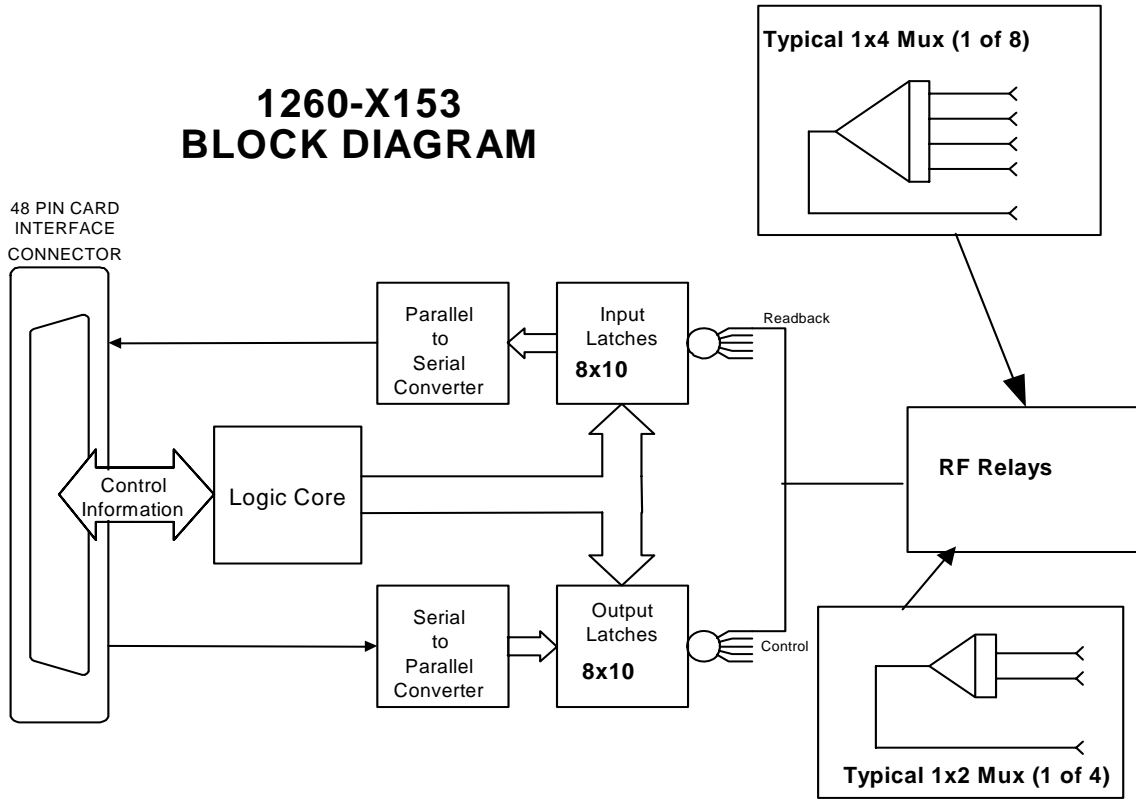

Figure 2-6, 1260-X153 Block Diagram

Chapter 3

MODULE OPERATION

Setting the Module Address

Both the Racal Instruments Option-01T and 1256 switch controllers identify each Adapt-a-Switch plug-in by a *module address* that is unique to that module.

For setting the module address of the 1260-X153 refer to the following manual.

- 1260-X100 Adapt-a-Switch Manual – Publication No. 980914-100X

VXI Operating Modes

The 1260-X153 may be operated either in *message-based* mode or in *register-based* mode when used with an Adapt-a-switch Carrier in a VXI chassis.

In the *message-based* mode, the 1260-01T switch controller interprets commands sent by the slot 0 controller, and determines the appropriate data to send to the control registers of the 1260-X153 module.

A conceptual view of the message-based mode of operation is shown in **Figure 3-1** below.

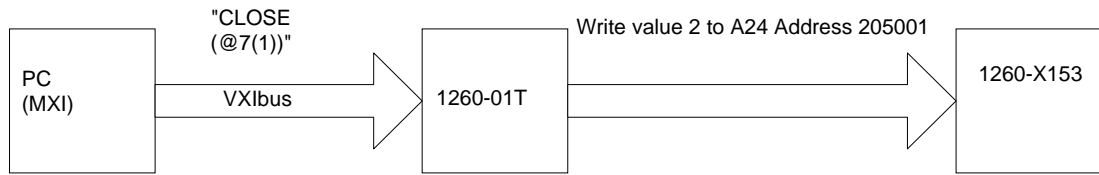

Figure 3-1, Message-Based Mode of Operation

In the *register-based* mode, the user writes directly to the control registers on the 1260-X153 module. The 1260-01T command module does not monitor these operations, and does not keep track of the relay states on the 1260-X153 module in this mode.

A conceptual view of the register-based mode is shown in **Figure 3-2** below.

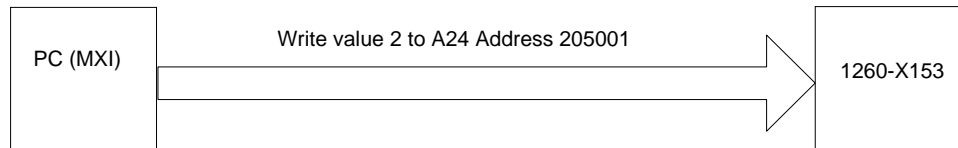

Figure 3-2, Register-Based Mode of Operation

Since the 1260-01T switch controller does not keep track of relay states during the register-based mode, it is advisable to use **either** the message-based or the register-based mode, and continue to use the same mode throughout the application program.

In general, the message-based mode of operation is easier to use with utility software such as the National Instruments VXI Interactive Control (VIC) program. The message-based mode allows the user to send ASCII text commands to the 1260-01T and to read replies from the 1260-01T. In addition, some features, such as the SCAN list, are available only in the message-based mode of operation.

The register-based mode provides faster control of relay channels. In this mode, relay operations are processed in less than 9 microseconds, not counting relay settling time or software overhead inherent in I/O libraries such as VISA. To determine the relay settling time, refer to Relay Settling Time in the Specifications section.

Consult the 1260-01T User's Manual for a comparison of the message-based and register-based modes of operation.

Operating In VXI Message-Based Mode

Channel Descriptors For The 1260-X153

The standard 1260-01T commands are used to operate the 1260-X153 module. These commands are described in the 1260-01T User's Manual.

Each 1260-01T relay command uses a *channel descriptor* to select the channel(s) of interest. The syntax for a channel descriptor is the same for all 1260 series modules. In general, the following syntax is used to select a single channel:

```
CLOSE(@ <module address>( <channel range> ) )
```

Where:

- <module address> is the address of the 1260-X153 module. This is a number in the range from 1 through 12, inclusive.
- <channel range> is a list of <channels> to operate.

When listing multiple channels, separate the channels with a comma (,). To select a contiguous range of channels, specify the first and last channels, and separate them by a colon (:)

- <channels> are defined by <mux> <sel>. Each channel is a three digit number specifying the multiplexer <mux> and the selected channel <sel> of the mux.
- <mux> valid designations are:
00, 01, 02, 03, 04, 05, 06, 07, 08, 09, 10, or 11
- <sel> there are two to four valid selected inputs designated:
0, 1, 2, or 3 for multiplexers 00 thru 07 and
0 or 1 for multiplexers 08 thru 11

The following examples illustrate the use of the channel descriptors for the 1260-X153, with a module address of 8.

OPEN (@8(000))	Open channel 0 of Mux 00 on the 1260-X153.
OPEN (@8(010))	Open channel 0 of Mux 01 on the 1260-X153.
CLOSE (@8(002))	Close channel 2 of Mux 00 on the 1260-X153.
CLOSE (@8(001,013))	Close channels 1 of Mux 00 and 3 of Mux 01 on the 1260-X153.

NOTES:

There can only be one selected input for each multiplexer. For example, if channel 001 is closed and channel 002 is commanded to close channel 001 will open by default.

As mentioned on the 1260-X153, two 1x4 multiplexers can be configured as a single 1x8. Also two 1x2 multiplexers can be configured as a 1x4.

The 1260-X153 uses “special” channel designators in order to configure these multiplexers. The following special syntax is used to configure the odd numbered multiplexers such that the closed channel is connected to the associated even mux common channel :

```
CLOSE (@<module address>(<mux_config>))
```

Where:

- <module address> is the address of the 1260-X153 module. This is a number in the range from 1 through 12, inclusive.
- <mux_config> is defined by <config> <odd_mux>. Each multiplexer configuration channel is a four digit number specifying the reconfiguration designator ‘10’ and the odd numbered multiplexer <odd_mux>.
- <config> valid designations is: 10

- <odd_mux> valid multiplexers are designated as:

01, 03, 05, 07, 09, 11

The following example illustrates the use of the special channel descriptor for the 1260-X153, with a module address of 8.

```
CLOSE (@8(1001,013))    Close channel 3 of Mux 1 to  
                        Common 00 channel on the  
                        1260-X153.
```

NOTES:

The special configuration channel must be OPEN to allow the even numbered multiplexers to connect to the common output. For example, if channel 1001 and channel 013 are closed, connecting 013 to the common output 00 and it is desired to connect channel 001 to common 00 then both channels 1001 and 013 should be opened followed by a close to channel 001.

Reply To The MOD:LIST? Command

The 1260-01T returns a reply to the MOD:LIST? command. This reply is unique for each different 1260 series switch module. The syntax for the reply is:

<module address> : <module-specific identification string>

The <module-specific identification string> for the 1260-X153 is:

```
1260-X153 8 1X4 4 1X2 RF MUX
```

So, for a 1260-X153 whose <module address> is set to 8, the reply to this query would be:

```
8 : 1260-X153 8 1X4 4 1X2 RF MUX
```

Operating in VXI Register-Based Mode

In register-based mode, the 1260-X153 is operated by directly writing and reading control registers on the 1260-X153 module. The first control register on the module operates control bits 0 through 7. The second control register operates control bits 8 through 15. When a control register is written to, all channels controlled by that register are operated simultaneously.

The control registers are located in the VXIbus A24 Address Space. The A24 address for a control register depends on:

1. The A24 Address Offset assigned to the 1260-01T module by the Resource Manager program. The Resource Manager program is provided by the VXIbus slot-0 controller vendor. The A24 Address Offset is placed into the "Offset Register" of the 1260-01T by the Resource Manager.
2. The <module address> of the 1260-X153 module. This is a value in the range from 1 and 12 inclusive.
3. The 1260-X153 control register to be written to or read from. Each control register on the 1260-X153 has a unique address.

The base A24 address for the 1260-X153 module may be calculated by:

$$(A24 \text{ Offset of the } 1260-01T) + (1024 \times \text{Module Address of } 1260-X153).$$

The A24 address offset is usually expressed in hexadecimal. A typical value of 204000_{16} is used in the examples that follow.

A 1260-X153 with a module address of 7 would have the base A24 address computed as follows:

$$\text{Base A24 Address of } 1260-X153 = 204000_{16} + (400_{16} \times 7_{10}) = 205C00_{16}$$

The control registers for Adapt-a-Switch plug-ins and conventional 1260-Series modules are always on odd-numbered A24 addresses. The ten control registers for the 1260-X153 reside at the first ten odd-numbered A24 addresses for the module:

$$(\text{Base A24 Address of } 1260-X153) + 1 = \text{Control Register 0}$$

$$(\text{Base A24 Address of } 1260-X153) + 3 = \text{Control Register 1}$$

$$(\text{Base A24 Address of } 1260-X153) + 5 = \text{Control Register 2}$$

$$(\text{Base A24 Address of } 1260-X153) + 7 = \text{Control Register 3}$$

(Base A24 Address of 1260-X153) + 9 = Control Register 4

(Base A24 Address of 1260-X153) + 11 = Control Register 5

(Base A24 Address of 1260-X153) + 13 = Control Register 6

(Base A24 Address of 1260-X153) + 15 = Control Register 7

(Base A24 Address of 1260-X153) + 17 = Control Register 8

(Base A24 Address of 1260-X153) + 19 = Control Register 9

So, for example, the first two control registers are located at:

205C01 Control Register 0, controls bits 0 through 7.

205C03 Control Register 1, controls bits 8 through 15.

Table 3-1 shows the bit and relay assignments for each control register.

Table 3-1, Control Register/Relay Assignments

Control Register	Relays							
	Bit 7 (MSB)	Bit 6	Bit 5	Bit 4	Bit 3	Bit 2	Bit 1	Bit 0 (LSB)
0	Not Used	Not Used	5	4	3	2	1	0
1	Not Used	14	13	12	11	10	9	8
2	Not Used	Not Used	21	20	19	18	17	16
3	Not Used	30	29	28	27	26	25	24
4	Not Used	Not Used	37	36	35	34	33	32
5	Not Used	46	45	44	43	42	41	40
6	Not Used	Not Used	53	52	51	50	49	48
7	Not Used	62	61	60	59	58	57	56
8	71	70	69	68	Not Used	66	65	64
9	79	78	77	76	Not Used	74	73	72

Setting a control bit to 1 closes the corresponding relay, and clearing the bit to zero opens the corresponding relay. Thus, if you write the value 0010 0100 binary = 36 decimal = 24 hexadecimal to Control Register 0, relays 2, and 5 will close, while relays 0, 1, 3, 4, 6, and 7 will open.

The present control register value may be read back by reading an 8-bit value from the control register address. **The value is inverted.** In other words, the eight-bit value read back is the one's complement of the value written.

If you want to change the state of a single relay without affecting the present state of the other relays controlled by the control register, you must:

1. Read the control register.
2. Invert the bits (perform a one's complement on the register data).
3. Perform a bit-wise AND operation, leaving all but the specific control register bit for the relay to change.
4. **To open:** continue to step 5. **To close:** OR in the bit for the relay to close.
5. Write the modified value back to the control register.

For example, to close channel 001:

1. Read Control Register 0 (this register controls relays 0 through 7, with relays 0 represented by the LSB).
2. Invert the bits in the value read in step 1.
3. AND with 1110 1101 binary (the zero is in the position corresponding to relays 1 and 4 to close channel 001).
4. OR with 0001 0010 binary.
5. Write the value to Control Register 0.

In order to control the relays the user should consult the relay diagrams **Figures 2-1, 2-2 and 2-3** in chapter 2, which shows the relationship between the connected paths and the associated relays.

Chapter 4

PRODUCT SUPPORT

Product Support

EADS North America Defense Test and Services, Inc. has a complete Service and Parts Department. If you need technical assistance or should it be necessary to return your product for repair or calibration, call 1-800-722-3262. If parts are required to repair the product at your facility, call 1-949-859-8999 and ask for the Parts Department.

When sending your instrument in for repair, complete the form in the back of this manual.

For worldwide support and the office closest to your facility, refer to the website for the most complete information <http://www.eads-nadefense.com>.

Warranty

Use the original packing material when returning the 1260-X153 to EADS North America Defense Test and Services, Inc. for calibration or servicing. The original shipping container and associated packaging material will provide the necessary protection for safe reshipment.

If the original packing material is unavailable, contact EADS North America Defense Test and Services, Inc. Customer Service at 1-800-722-3262 for information.

REPAIR AND CALIBRATION REQUEST FORM

To allow us to better understand your repair requests, we suggest you use the following outline when calling and include a copy with your instrument to be sent to the EADS North America Defense Test and Service, Inc. Repair Facility.

Model _____ Serial No. _____ Date _____

Company Name _____ Purchase Order # _____

Billing Address _____

City

State/Province

Zip/Postal Code

Country

Shipping Address _____

City

State/Province

Zip/Postal Code

Country

Technical Contact _____ Phone Number () _____

Purchasing Contact _____ Phone Number () _____

1. Describe, in detail, the problem and symptoms you are having. Please include all set up details, such as input/output levels, frequencies, waveform details, etc.

2. If problem is occurring when unit is in remote, please list the program strings used and the controller type.

3. Please give any additional information you feel would be beneficial in facilitating a faster repair time (i.e., modifications, etc.)

4. Is calibration data required? Yes No (please circle one)

Call before shipping
Note: We do not accept
"collect" shipments.

Ship instruments to nearest support office.